

## SINGLE SUPPLY QUAD OPERATIONAL AMPLIFIER

### ■ GENERAL DESCRIPTION

The NJM12902 is single-supply quad operational amplifier, which can operate from 2V supply. The features are low offset voltage, low bias current, and drive TTL or DTL circuit directly. The package lineup is DMP and others compact, so that the NJM12902 is suitable for audio for low voltage operation and any other kind of signal amplifier.

### ■ FEATURES

- Operating Voltage ( +2V~+14V )
- Input Offset Voltage ( 5mV max. )
- Slew Rate ( 0.7V/μs typ. )
- Operating Current ( 1.0mA typ. )
- Bipolar Technology
- Package Outline
 

|           |        |
|-----------|--------|
| NJM12902M | DMP14  |
| NJM12902E | EMP14  |
| NJM12902V | SSOP14 |

### ■ PACKAGE OUTLINE

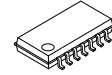

NJM12902M

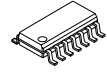

NJM12902E



NJM12902V

### ■ PIN CONFIGURATION

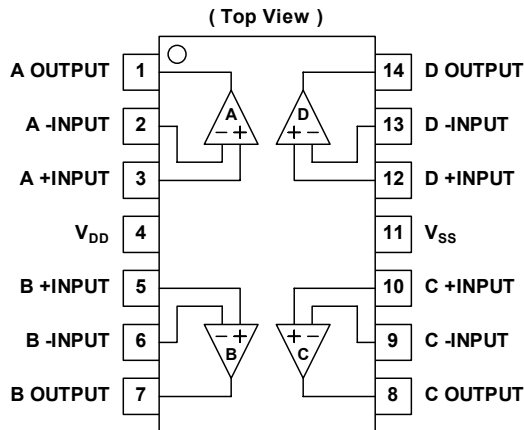

### ■ EQUIVALENT CIRCUIT ( 1/4 Shown )

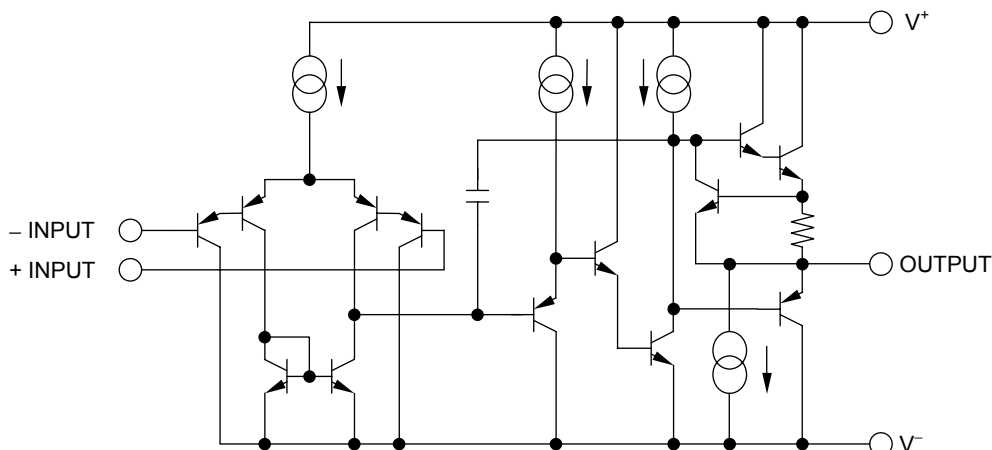

# NJM12902

## ■ ABSOLUTE MAXIMUM RATINGS

( Ta=25°C )

| PARAMETER                   | SYMBOL           | RATINGS  | UNIT |
|-----------------------------|------------------|--|------|
| Supply Voltage              | V <sup>+</sup>   | 15   | V    |
| Differential Input Voltage  | V <sub>ID</sub>  | 14   | V    |
| Input Voltage               | V <sub>IC</sub>  | -0.3~+14   | V    |
| Power Dissipation           | P <sub>D</sub>   | ( DMP14 ) 300<br>( EMP14 ) 300<br>( SSOP14 ) 300 | mW   |
| Operating Temperature Range | T <sub>opr</sub> | -40~+85  | °C   |
| Storage Temperature Range   | T <sub>stg</sub> | -50~+125   | °C   |

## ■ ELECTRICAL CHARACTERISTICS

( V<sup>+</sup>=5V, Ta=25°C )

| PARAMETER                       | SYMBOL              | TEST CONDITION   | MIN.  | TYP. | MAX. | UNIT |
|---------------------------------|---------------------|--|-------|------|------|------|
| Operating Voltage               | V <sub>opr</sub>    |  | 2     | -    | 14   | V    |
| Input Offset Voltage            | V <sub>IO</sub>     | R <sub>S</sub> =0Ω   | -     | 1    | 5    | mV   |
| Input Offset Current            | I <sub>IO</sub>     |  | -     | 5    | 50   | nA   |
| Input Bias Current              | I <sub>B</sub>      |  | -     | 20   | 150  | nA   |
| Large Signal Voltage Gain       | A <sub>V</sub>      | R <sub>L</sub> ≥2kΩ  | -     | 100  | -    | dB   |
| Maximum Output Voltage Swing    | V <sub>OM</sub>     | R <sub>L</sub> =2kΩ  | 3.5   | -    | -    | V    |
| Input Common Mode Voltage Range | V <sub>ICM</sub>    |  | 0~3.5 | -    | -    | V    |
| Common Mode Rejection Ratio     | CMR                 |  | -     | 85   | -    | dB   |
| Supply Voltage Rejection Ratio  | SVR                 |  | -     | 100  | -    | dB   |
| Output Source Current           | I <sub>SOURCE</sub> | V <sub>IN</sub> <sup>+</sup> =1V, V <sub>IN</sub> <sup>-</sup> =0V           | 20    | 40   | -    | mA   |
| Output Sink Current             | I <sub>SINK</sub>   | V <sub>IN</sub> <sup>+</sup> =0V, V <sub>IN</sub> <sup>-</sup> =1V           | 8     | 30   | -    | mA   |
| Channel Separation              | CS                  | f=1k~20kHz   | -     | 120  | -    | dB   |
| Operating Current               | I <sub>CC</sub>     | R <sub>L</sub> =∞  | -     | 1.0  | 2.0  | mA   |
| Slew Rate                       | SR                  | V <sup>+</sup> /V=±2.5V,<br>R <sub>L</sub> =2kΩ, A <sub>V</sub> =0dB, f=1kHz | -     | 0.7  | -    | V/μs |
| Gain Bandwidth Product          | GB                  |  | -     | 1.5  | -    | MHz  |

## ■ TYPICAL CHARACTERISTICS

**Operating Current vs. Operating Voltage**  
( $T_a=25^\circ\text{C}$ )

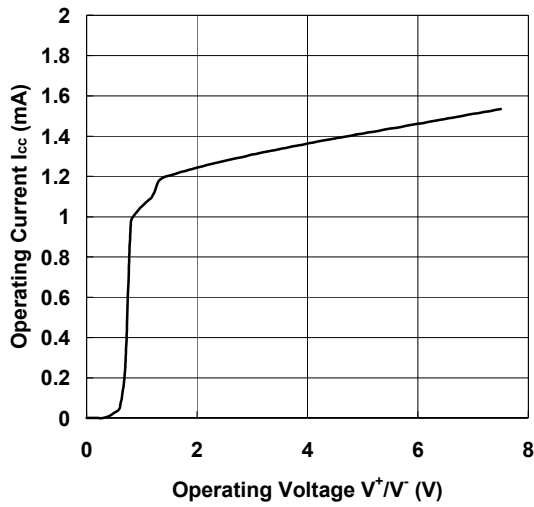

**Input Offset Voltage vs. Operating Voltage**  
( $T_a=25^\circ\text{C}$ )

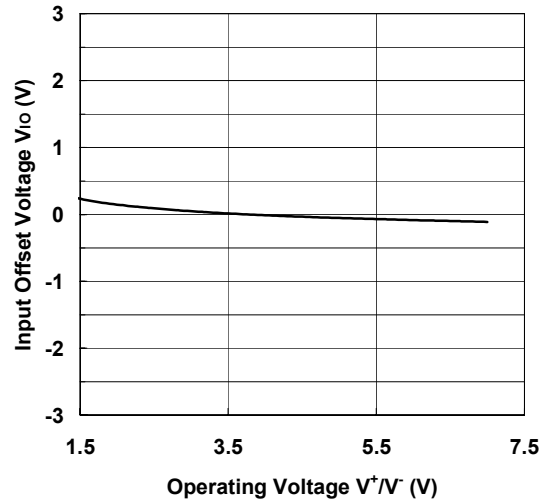

**Input Bias Current vs. Operating Voltage**  
( $T_a=25^\circ\text{C}$ )

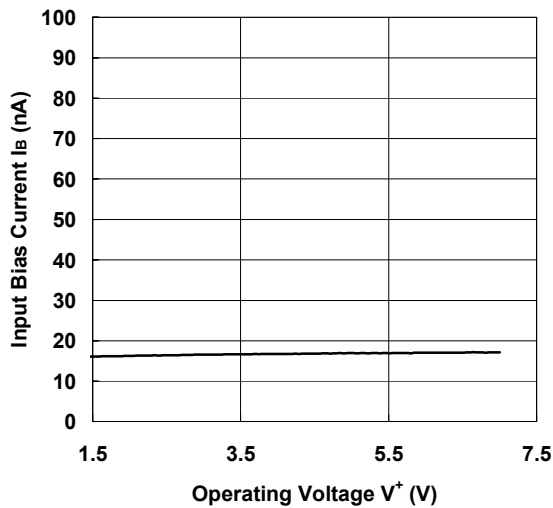

**Maximum Output Voltage vs. Operating Voltage**  
( $T_a=25^\circ\text{C}$ )

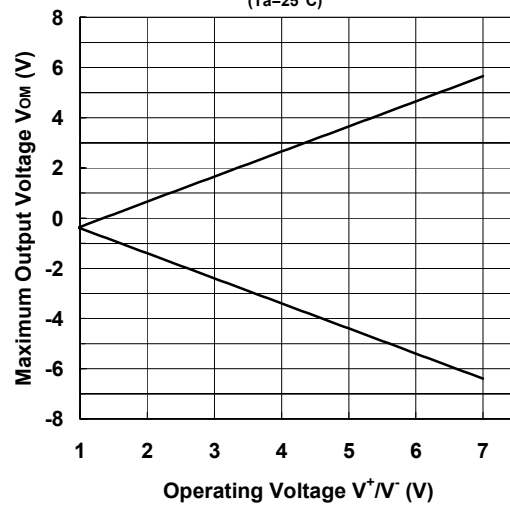

**Input offset Voltage vs. Input voltage**  
( $V^+=5\text{V}$ ,  $T_a=25^\circ\text{C}$ )

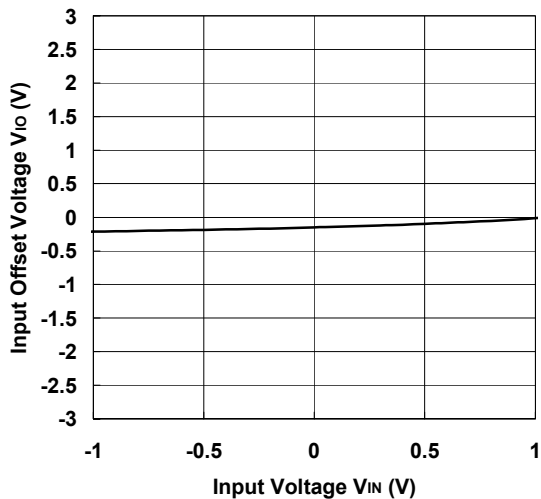

**Maximum Output Voltage vs. Frequency**  
( $T_a=25^\circ\text{C}$ )

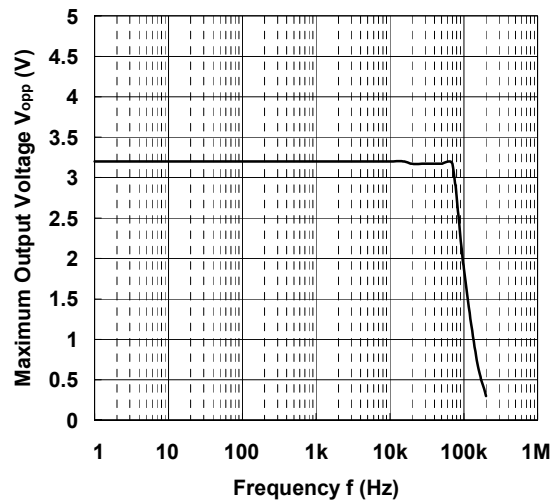

## ■ TYPICAL CHARACTERISTICS

Output Voltage vs. Output Sink Current  
( $T_a=25^\circ\text{C}$ )

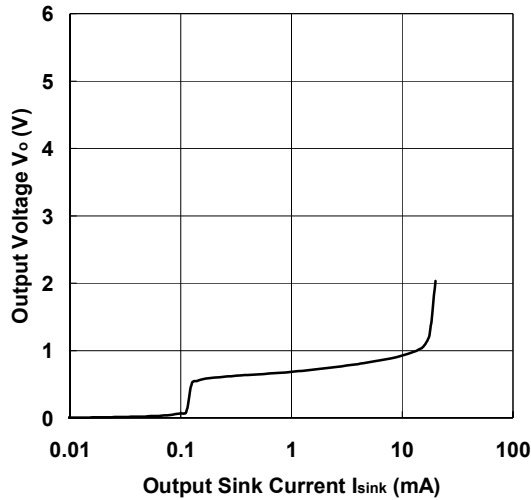

Output Voltage vs. Output Source Current  
( $T_a=25^\circ\text{C}$ )

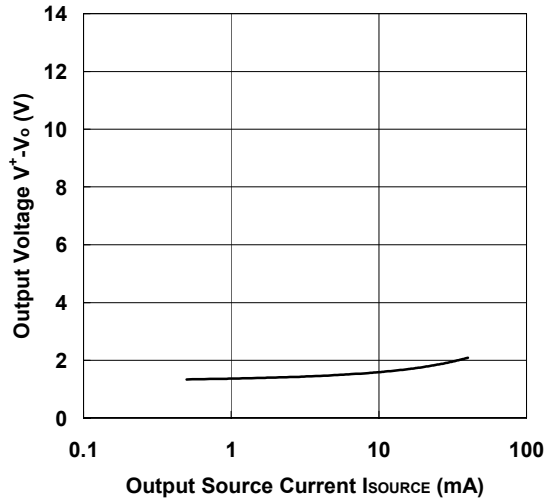

Voltage Gain vs. Operating Voltage  
( $R_L=2\text{k}\Omega$ ,  $T_a=25^\circ\text{C}$ )

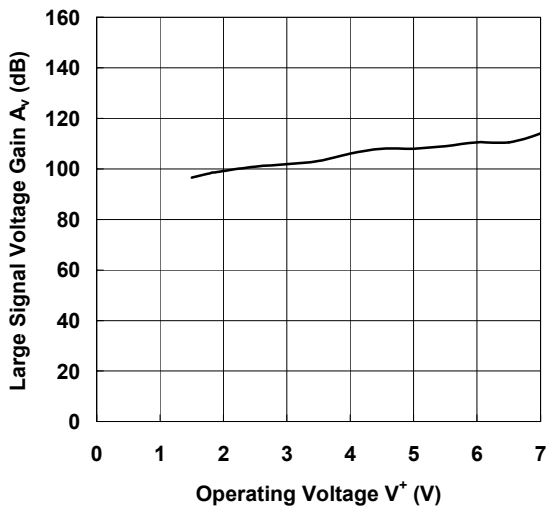

Voltage Gain / Phase vs. Frequency  
( $T_a=25^\circ\text{C}$ )

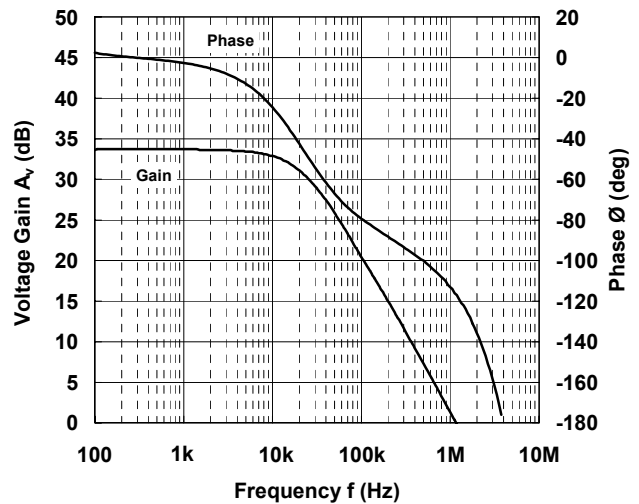

Slew Rate (Rise)

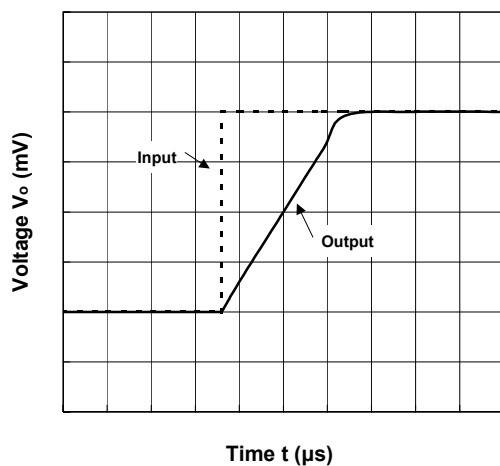

Slew Rate (Fall)

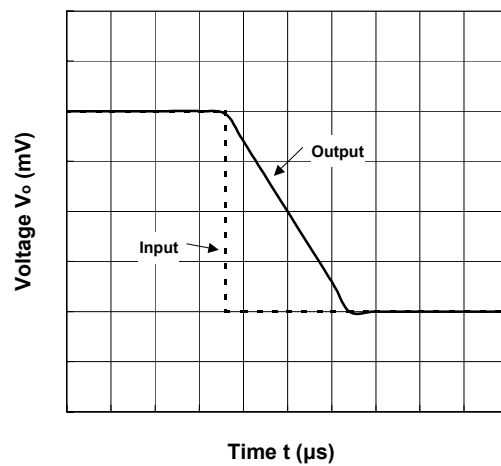

## ■ TYPICAL CHARACTERISTICS

Operating Current vs. Ambient Temperature

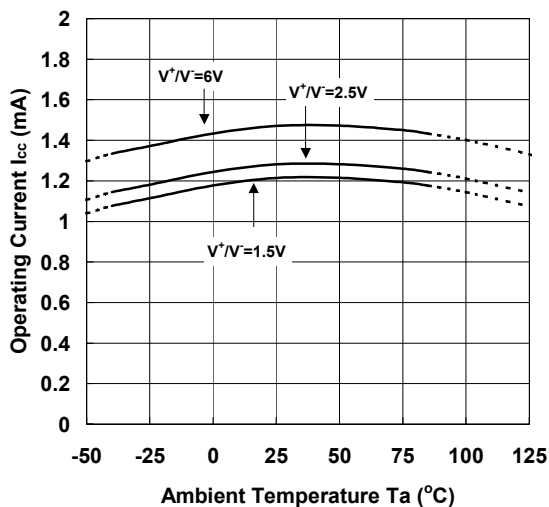

Input Offset Voltage vs. Ambient Temperature

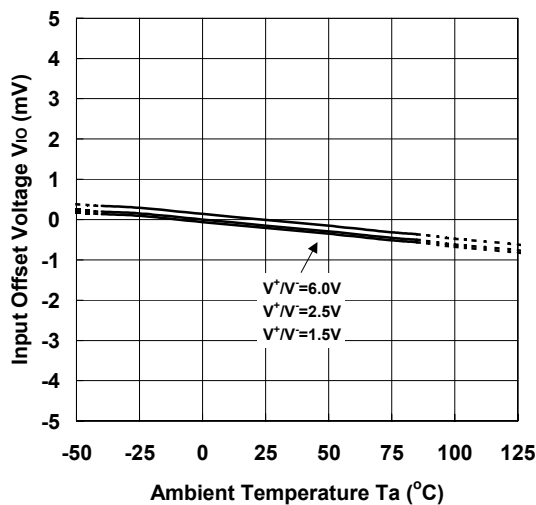

Input Bias Current vs. Ambient Temperature

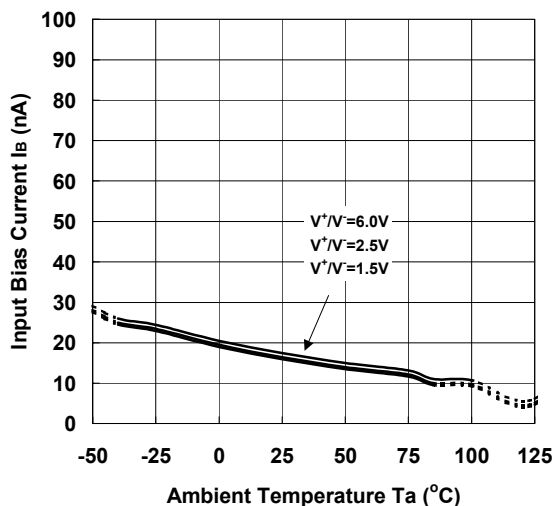

Maximum Output Voltage v.s Temperature

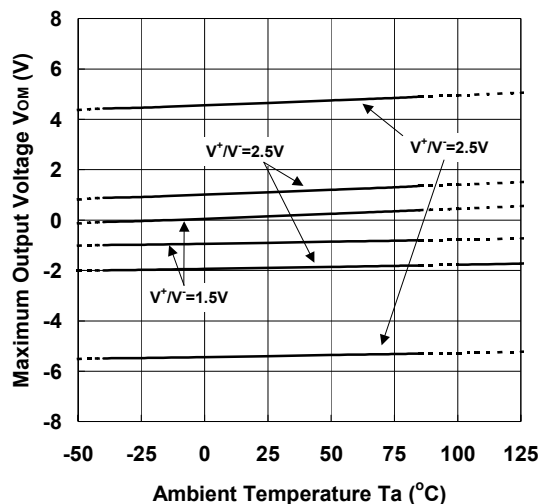

Output Sink Current vs. Ambient Temperature

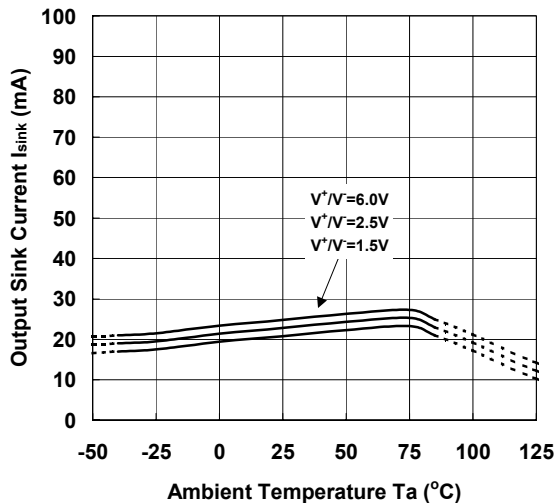

Output Source Current vs. Ambient Temperature

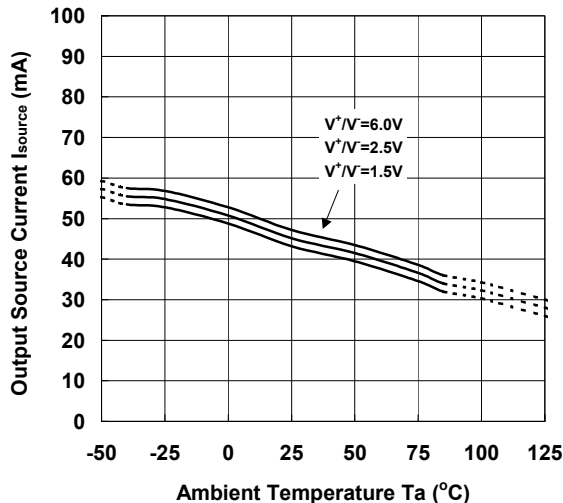

## ■ TYPICAL CHARACTERISTICS

Large Signal Voltage Gain vs. Ambient Temperature

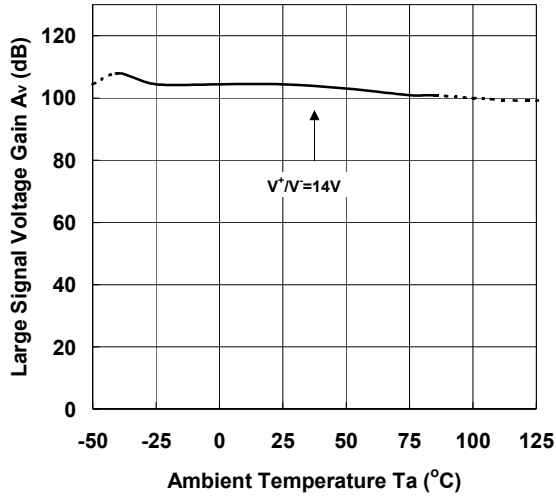

Common Mode Rejection Ratio v.s Ambient Temperature

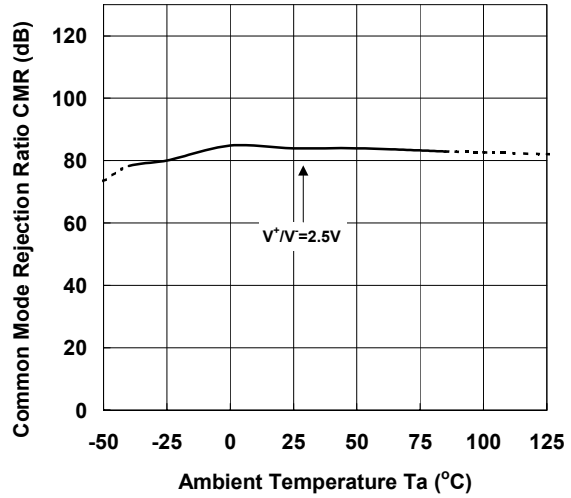

Supply Voltage Rejection Ratio v.s Ambient Temperature

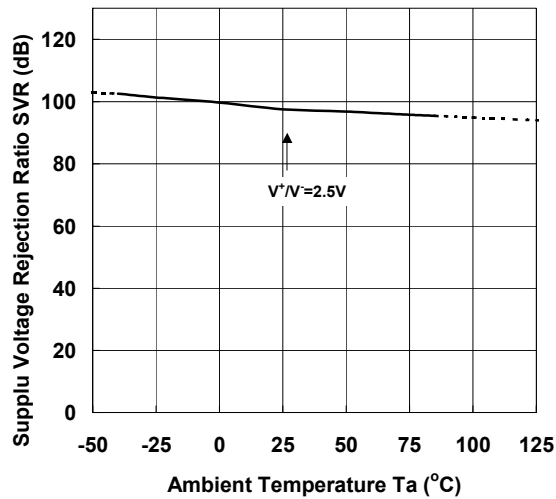

**[CAUTION]**

The specifications on this data book are only given for information, without any guarantee as regards either mistakes or omissions. The application circuits in this data book are described only to show representative usages of the product and not intended for the guarantee or permission of any right including the industrial rights.